

# eleofire

BEYOND EXPECTATION





# The warmest of welcomes

Welcome the warmth of Elcofire into your home with fires and stoves that embody elegance and epitomise efficiency.

Born out of our passion for precision engineering, our expert team has combined their collective industry knowledge, technical expertise, and customer experience to deliver products unparalleled in their design.

Our commitment to quality and sustainability means we use only the best available components and state-of-the-art manufacturing techniques to create beautiful products that will last a lifetime and beyond, providing your home with years of comfort and warmth.

BEYOND  
EXPECTATION

# OUR SERVICE PILLARS

**We have three key principles that we stand by in the design and supply of our products and services. These service pillars help us to deliver the quality experience our customers both deserve and have come to expect.**

## **Style**

Whether a cabin or a cottage, a house or a high-rise apartment, we believe each of our products should fit effortlessly into our modern ways of living, offering a contemporary elegance and stylish aesthetic that brings a unique warmth to every home.

## **Sustainability**

Creating the best fires for our customers also means designing the best products for the world we live in. That means pushing the boundaries not only of energy efficiency, but of longevity, sourcing components and using modern manufacturing techniques to come up with products that will last lifetimes.

## **Service**

Warmth is not simply what our products deliver. It is a key component of the service we provide to our customers, with installation guides, service aftercare, and warranties that enable our team to provide the highest, most human level of care.

# OUR SUSTAINABILITY COMMITMENT

The EU Ecodesign Directive obliges manufacturers to design energy-using products that consume less energy and improve air quality throughout their life cycle. All Elcofire fires and stoves conform to this legislation and carry Ecodesign Directive energy labelling.



## High Efficiency

All Elcofire products have been designed to operate with high thermal efficiency, minimising the loss of heat energy during use. Every model in this brochure is subject to EU energy labelling standards and almost all are rated as either A or A+ energy class appliances.

## Defra Exempt

Most town and city homes are located in Smoke Control Areas. To burn logs in these locations, the stove installed must be granted exemption from these restrictions by the government through DEFRA (Department for Environment Food and Rural Affairs in the UK). Independently tested to demonstrate particularly clean burning combustion, Elcofire stoves have DEFRA exemption.

## Eco Design

All Elcofire stoves meet the stringent air quality standards of Ecodesign, featuring Cleanburn technology for high-efficiency heating in Smoke Control Areas. They also meet, and in many cases exceed, Ecodesign emission and efficiency standards. Our low-emission stoves reduce particulates by up to 84% compared with old appliances.

# OUR PROMISE

## SOLID FUEL WARRANTY

Elcofire Stoves are a quality product with a 5-year warranty for your peace of mind, which covers all stove body castings. This does not include consumable items as such as glass, door seals, grates, firebricks, vermiculite panels, baffles and log guards.

## PELLET FIRE WARRANTY

Elcofire Pellet Stoves are a quality product with a 2-year warranty for your peace of mind, which covers all stove body castings. This does not include consumable items as such as glass, door seals, grates, firebricks, vermiculite panels, baffles and log guards, electrical components, all electrical components are guaranteed for 1 year.

## ELECTRIC FIRE WARRANTY

Elcofire Electric Fire are a quality product with a 2-year warranty for your peace of mind, which covers all components excluding the Glass.

## PRODUCT SPECIFICATIONS

Elcofire products represent the cutting edge in low-emission stoves, with an assortment of features across our range that deliver comfort in the home and environmental sustainability to the world.



Remote Control



Wi-Fi Enabled



Elcofire Clean Glass Technology



External Air



Eco Design Ready



Multi Fuel



Defra Exempt



Sustainable



# electric

Complemented by ultra-realistic, illuminated pulsating logs and fuel bed, the Elcofire Motion® range boasts the cleanest built-in design, as well as flames so tall and lifelike that they rival the experience of a real fire.



EFM700

# Motion<sup>®</sup> - 700

A+

## KEY FEATURES

- Motion™ Flame and Log Technology
- Ultra-Realistic Illuminated Glowing/Pulsating Log Set
- 10 Unique Flame Colours with Down Lighting and Ember Bed Lighting
- Black Acrylic Crystal Ember Bed
- Low Energy LED Flame Technology
- Hidden Manual Touch Screen Button Controls
- New Sleek Remote
- Can be Installed Beneath a TV
- Variable Heat with Thermostat with built in timer
- Variable Flame Controls
- 220 Volt Plug
- Do it Yourself Installation Instructions
- 4-Sided Finish Trim Kit Included



elcofire





EFM1100

# Motion® - 1100

A+

## KEY FEATURES

- Motion™ Flame and Log Technology
- Ultra-Realistic Illuminated Glowing/Pulsating Log Set
- 10 Unique Flame Colours with Down Lighting and Ember Bed Lighting
- Black Acrylic Crystal Ember Bed
- Low Energy LED Flame Technology
- Hidden Manual Touch Screen Button Controls
- New Sleek Remote
- Can be Installed Beneath a TV
- Variable Heat with Thermostat with built in timer
- Variable Flame Controls
- 220 Volt Plug
- Do it Yourself Installation Instructions
- 4-Sided Finish Trim Kit Included





EFM1500

# Motion<sup>®</sup> - 1500

A+

## KEY FEATURES

- Motion™ Flame and Log Technology
- Ultra-Realistic Illuminated Glowing/Pulsating Log Set
- 10 Unique Flame Colours with Down Lighting and Ember Bed Lighting
- Black Acrylic Crystal Ember Bed
- Low Energy LED Flame Technology
- Hidden Manual Touch Screen Button Controls
- New Sleek Remote
- Can be Installed Beneath a TV
- Variable Heat with Thermostat with built in timer
- Variable Flame Controls
- 220 Volt Plug
- Do it Yourself Installation Instructions
- 4-Sided Finish Trim Kit Included



elcofire



# solid fuel

The Eco Stove Range from Elcofire incorporates our unique efficient fuel burning technology, which conforms to EU Ecodesign standards and allows wood to be burnt cleanly and safely in Smoke Control Areas.



EFLGW

# Luna Inset Glass

A+

## KEY FEATURES

- Fuel: Wood or Smokeless Fuel
- Heat Output: Wood-5kw/Smokeless 6kw
- Efficiency: 83.0%
- Flue Size: 125mm
- Extra-large glass door
- Sleek contemporary design
- Outstanding efficiency
- Elcofire Clean Glass Technology
- Available with 3 or 4 sided frames
- Cool touch handle
- External air
- Ecodesign Ready
- Easy to light and install

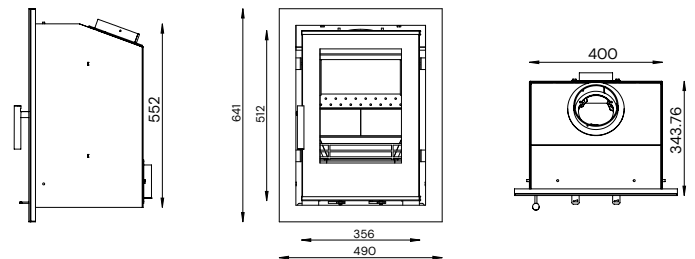

elcofire



EFLCW

# Luna Inset – Cast Iron

A+

## KEY FEATURES

- Fuel: Wood or Smokeless Fuel
- Heat Output: Wood-5kw/Smokeless 6kw
- Efficiency: 83.0%
- Flue Size: 125mm
- Extra-large glass door
- Sleek contemporary design
- Outstanding efficiency
- Elcofire Clean Glass Technology
- Available with 3 or 4 sided frames
- Cool touch handle
- External air
- Ecodesign Ready
- Easy to light and install

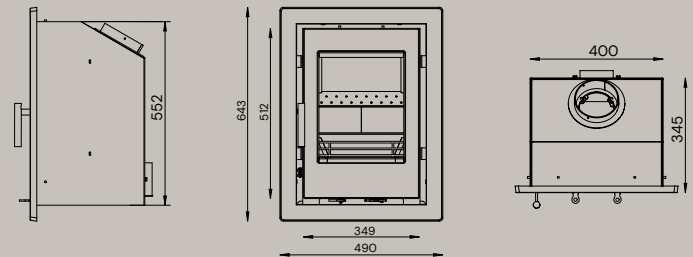



EFTW

# Terra Freestanding

A+

## KEY FEATURES

- Fuel: Wood or Smokeless Fuel
- Heat Output: Wood-6kw/Smokeless 7.5kw
- Efficiency: 83.9%
- Flue Size: 125mm
- Extra-large glass door
- Sleek contemporary design
- Outstanding efficiency
- Elcofire Clean Glass Technology
- Available with or without Multifuel Kit
- Cool touch handle
- External air
- Ecodesign Ready
- Easy to light and install

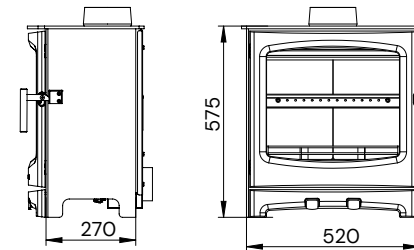

elcofire



# pellet stoves

The Elcofire Eco Pellet stove range is stylish, efficient, and robust. Its patented air technology with forced ventilation is whisper-quiet and suited to any room in the home, with Wi-Fi and remote control as standard for total comfort and convenience.



EFLIP

# Lima Inset Stove

The Lima Inset Pellet Stove is the smallest of its kind that can be retrofitted into a standard fireplace with a robust design and an easy slide out drawer to load your pellets.

A+

## KEY FEATURES

- 3.0kw – 6.5kw Output
- Wi Fi enabled & remote control as standard
- Built in 3 Button Display Touch Panel
- Daily & Weekly Programmer
- Stainless Steel Burning Pot
- Pellet consumption per hour: Max 1.0 kg/h – Min 0.5 kg/h
- Pellet tank capacity: 8 kg
- Heated room size: 70 – 160 mc
- Easy Slide Out Loading Drawer to fill up with pellets
- Available with 3 or 4 sided frames

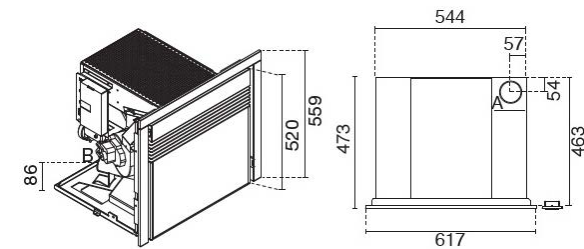

elcofire





EFKIP

# Kiva freestanding stove

A+

The Kiva is a small compact pellet stove with an enhanced thermal exchanger ensures maximum heat transfer while minimizing fuel consumption.

## KEY FEATURES

- 2.5kw – 8.0kw Output
- Wi Fi enabled & Remote Control as standard
- 3 Button Display Touch Panel
- Daily & Weekly Programmer
- Stainless Steel Burning Pot
- Pellet consumption per hour: Max 2.0 kg/h – Min 0.6 kg/h
- Pellet tank capacity: 11 kg
- Heated Room Size: 140 – 200 mc

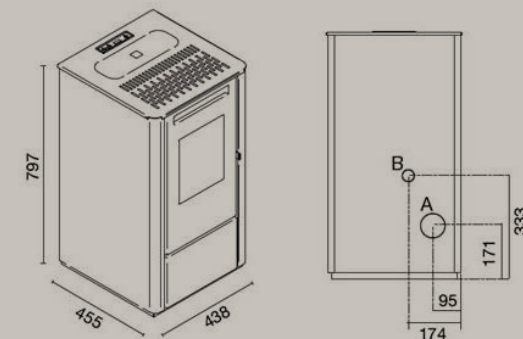



EFADP

# Aden slimline freestanding

A+

The Aden is a small slim pellet stove that can sit neatly on your floor or in front of an open fire on your existing hearth with heat at a touch of button.

## KEY FEATURES

- 2.1kw – 4.6kw Output
- Wi Fi enabled & remote control as standard
- 3 Button Display Touch Panel
- Daily & Weekly Programmer
- Measurements: W 559mm x D 265mm x H 694 mm
- Stainless Steel Burning Pot
- Smoke output: Rear & Side Option
- Pellet consumption per hour: Max 1.0 kg/h – Min 0.5 kg/h
- Pellet tank capacity: 4.7 kg
- Heated room size: 40 – 100 mc

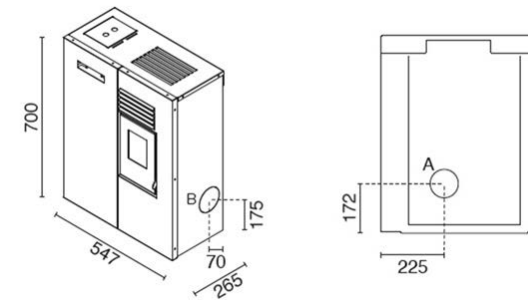

elcofire



BEYOND  
EXPECTATION

# elcofire

BEYOND EXPECTATION

YOUR DEDICATED SALES AGENT:

[elcofire.com](https://elcofire.com)    

Elcofire is part of the Nedar Heat Company